

# TOPHiKu6

N-type TOPCon Technology

595 W ~ 620 W

CS6.1-72TD-595 | 600 | 605 | 610 | 615 | 620

## MORE POWER



Module power up to 620 W  
Module efficiency up to 23.0 %



Excellent anti-LeTID & anti-PID performance.  
Low power degradation, high energy yield



Lower temperature coefficient (Pmax): -0.29%/°C,  
increases energy yield in hot climate



Lower LCOE & system cost

## MORE RELIABLE



Minimizes micro-crack impacts



Heavy snow load up to 5400 Pa,  
wind load up to 2400 Pa\*



**Enhanced Product Warranty on Materials and Workmanship\***



**Linear Power Performance Warranty\***

**1<sup>st</sup> year power degradation no more than 1%  
Subsequent annual power degradation no more than 0.4%**

\*According to the applicable Canadian Solar Limited Warranty Statement.

## MANAGEMENT SYSTEM CERTIFICATES\*

ISO 9001:2015 / Quality management system  
ISO 14001:2015 / Standards for environmental management system  
ISO 45001: 2018 / International standards for occupational health & safety  
IEC62941: 2019 / Photovoltaic module manufacturing quality system

## PRODUCT CERTIFICATES\*

\* The specific certificates applicable to different module types and markets will vary, and therefore not all of the certifications listed herein will simultaneously apply to the products you order or use. Please contact your local Canadian Solar sales representative to confirm the specific certificates available for your Product and applicable in the regions in which the products will be used.

**CSI Solar Co., Ltd.** is committed to providing high quality solar photovoltaic modules, solar energy and battery storage solutions to customers. The company was recognized as the No. 1 module supplier for quality and performance/price ratio in the IHS Module Customer Insight Survey. Over the past 22 years, it has successfully delivered over 100 GW of premium-quality solar modules across the world.

\* For detailed information, please refer to the Installation Manual.

## ENGINEERING DRAWING (mm)

### Rear View

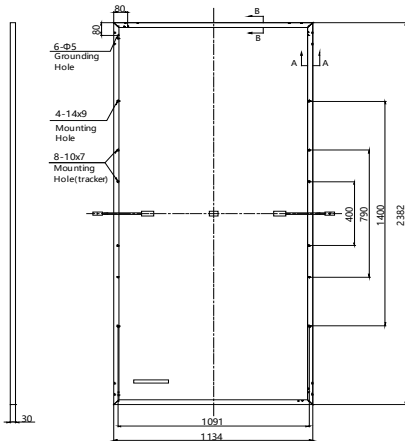

### Frame Cross Section

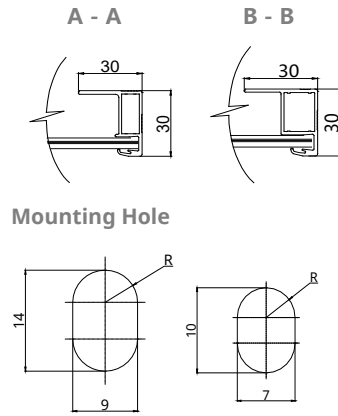

## CS6.1-72TD-600 / I-V CURVES

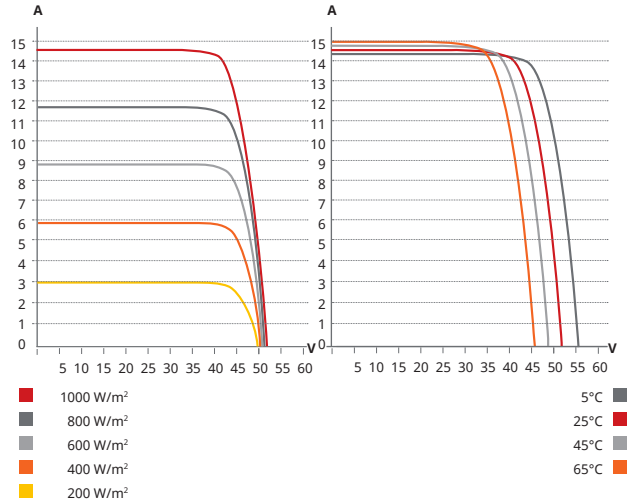

## ELECTRICAL DATA | STC\*

CS6.1-72TD	595	600	605	610	615	620
Nominal Max. Power (Pmax)	595 W	600 W	605 W	610 W	615 W	620 W
Opt. Operating Voltage (Vmp)	43.8 V	44.0 V	44.2 V	44.4 V	44.6 V	44.8 V
Opt. Operating Current (Imp)	13.59 A	13.64 A	13.69 A	13.74 A	13.79 A	13.84 A
Open Circuit Voltage (Voc)	51.6 V	51.8 V	52.0 V	52.2 V	52.4 V	52.6 V
Short Circuit Current (Isc)	14.48 A	14.54 A	14.60 A	14.66 A	14.72 A	14.78 A
Module Efficiency	22.0%	22.2%	22.4%	22.6%	22.8%	23.0%
Operating Temperature	-40°C ~ +85°C					
Max. System Voltage	1500V (IEC/UL) or 1000V (IEC/UL)					
Module Fire Performance	TYPE 29 (UL 61730) or CLASS C (IEC 61730)					
Max. Series Fuse Rating	25 A					
Application Classification	Class A					
Power Tolerance	0 ~ + 10 W					

\* Under Standard Test Conditions (STC) of irradiance of 1000 W/m<sup>2</sup>, spectrum AM 1.5 and cell temperature of 25°C.

## ELECTRICAL DATA | NMOT\*

CS6.1-72TD	595	600	605	610	615	620
Nominal Max. Power (Pmax)	450 W	454 W	458 W	461 W	465 W	469 W
Opt. Operating Voltage (Vmp)	41.4 V	41.6 V	41.8 V	42.0 V	42.2 V	42.4 V
Opt. Operating Current (Imp)	10.87 A	10.91 A	10.95 A	10.99 A	11.03 A	11.07 A
Open Circuit Voltage (Voc)	48.9 V	49.0 V	49.2 V	49.4 V	49.6 V	49.8 V
Short Circuit Current (Isc)	11.68 A	11.73 A	11.77 A	11.82 A	11.87 A	11.92 A

\* Under Nominal Module Operating Temperature (NMOT), irradiance of 800 W/m<sup>2</sup>, spectrum AM 1.5, ambient temperature 20°C, wind speed 1 m/s.

## MECHANICAL DATA

Specification	Data
Cell Type	TOPCon cells
Cell Arrangement	144 [2 x (12 x 6) ]
Dimensions	2382 × 1134 × 30 mm (93.8 × 44.6 × 1.18 in)
Weight	33.6 kg (74.1 lbs)
Front Glass	2.0 mm heat strengthened glass with anti-reflective coating
Back Glass	2.0 mm heat strengthened glass
Frame	Anodized aluminium alloy
J-Box	IP68, 3 bypass diodes
Cable	4 mm <sup>2</sup> (IEC), 12 AWG (UL)
Cable Length (Including Connector)	350 mm (13.8 in) (+) / 250 mm (9.8 in) (-) or customized length*
Connector	T6 or MC4-EVO2 or MC4-EVO2A
Per Pallet	36 pieces
Per Container (40' HQ)	720 pieces

\* For detailed information, please contact your local Canadian Solar sales and technical representatives.

## TEMPERATURE CHARACTERISTICS

Specification	Data
Temperature Coefficient (Pmax)	-0.29 % / °C
Temperature Coefficient (Voc)	-0.25 % / °C
Temperature Coefficient (Isc)	0.05 % / °C
Nominal Module Operating Temperature	41 ± 3°C

## PARTNER SECTION



\* The specifications and key features contained in this datasheet may deviate slightly from our actual products due to the on-going innovation and product enhancement. CSI Solar Co., Ltd. reserves the right to make necessary adjustment to the information described herein at any time without further notice.

Please be kindly advised that PV modules should be handled and installed by qualified people who have professional skills and please carefully read the safety and installation instructions before using our PV modules.